

A22060



Ø220x60mm
(Ø8.60"x2.36")



HOUSING	Aluminum Die Casting, Painted Black
IMPELLER	Thermoplastic PBT, UL94V-0
BEARING	Ball
MOTOR TYPE	Shaded Pole Motor
TERMINATION	Lead Wire
OPERATING VOLTAGE RANGE	85VAC to 125VAC for 115V Type 185VAC to 245VAC for 230V Type
DIELECTRIC STRENGTH	1,500VAC for 1 second
INSULATION	Class A
INSULATION RESISTANCE	10M Ohms Min. @500 VDC
OPERATING TEMPERATURE	-10°C to + 70°C
SAFETY	Impedance Protected
WEIGHT	1400g
ROHS COMPLIANCE	Yes

DIMENSION

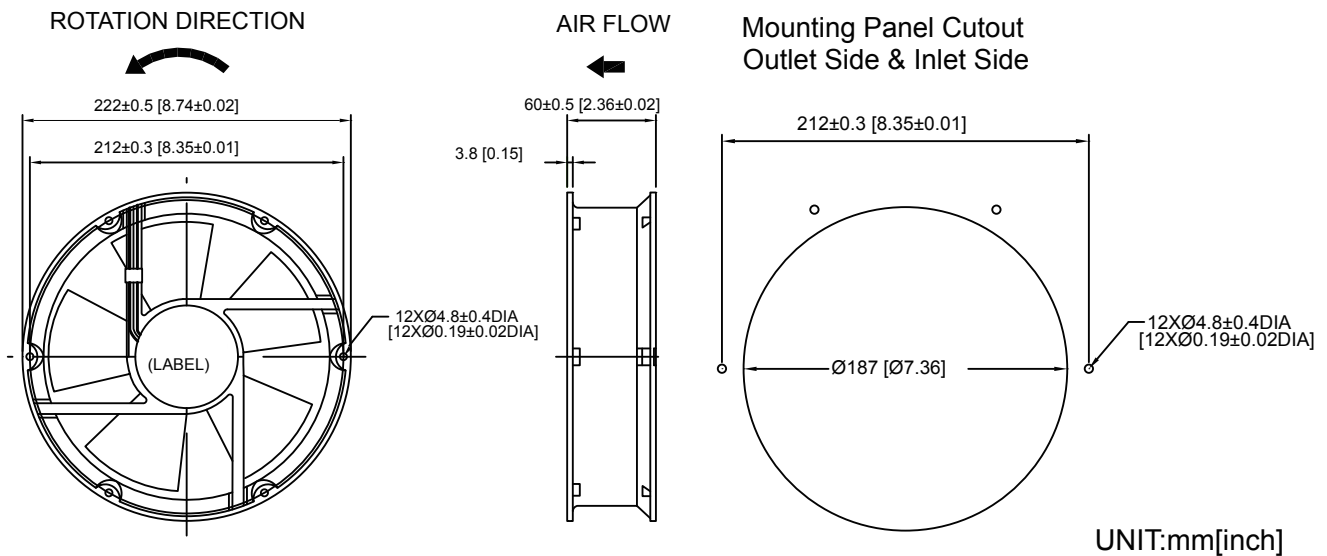

SPECIFICATION

MODEL NO.	RATED VOLTAGE (V)	FREQUENCY (Hz)	RATED CURRENT (A)	INPUT POWER (W)	SPEED (RPM)	MAX. AIR PRESSURE		MAX. AIR FLOW		NOISE dB(A) @1M
						inchH ₂ O	mmH ₂ O	CFM	m ³ /min	
A22060V1H	115	50/60	0.60/0.60	40/40	2600/2200	0.22/0.11	5.5/2.8	360/340	10.19/9.62	56
A22060V2H	230	50/60	0.35/0.32	44/44	2600/2700	0.22/0.11	5.5/2.8	360/340	10.19/9.62	56

AIR PERFORMANCE

