

AC Current Transformers 50/60Hz

CT09-7 Series

RoHS Compliant

CE/UL- Approved

Part Number	Electrical Characteristic				Photo
	Current Ratio	Accuracy Class (%)	Turns Ratio (Np:Ns)	RL (Ω)	
CT097100P	30A/ 30mA	0.2	1: 1000	100	
CT097150P	35A/ 23.3mA	0.2	1: 1500	100	
CT097200P	50A/ 25mA	0.2	1: 2000	100	
CT097250P	80A/ 32mA	0.2	1: 2500	100	
CT097100S	60A/ 60mA	1	1: 1000	100	
CT097150S	75A/ 50mA	1	1: 1500	100	
CT097200S	100A/ 50mA	0.5	1: 2000	100	
CT097250S	150A/ 60mA	0.5	1: 2500	100	

Mechanical Dimensions in mm

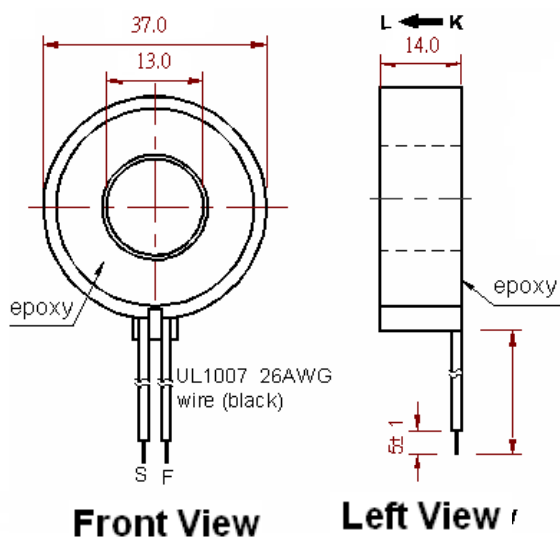

Test Circuit

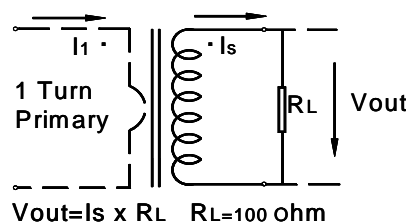

AC Current Transformers 50/60Hz

CT09-7 Series

RoHS Compliant

CE/UL- Approved

